

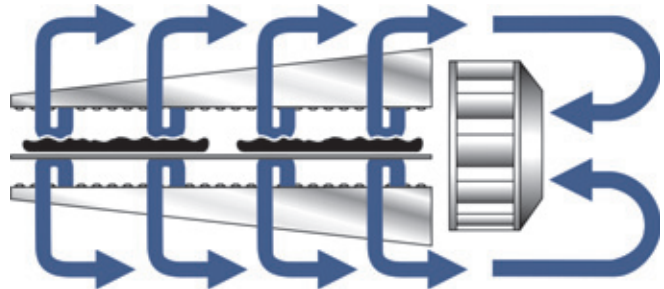

Principle

Middleby Marshall PS Series conveyor ovens bake both faster and at a lower temperature than other ovens. Vertical columns of hot air move heat aerodynamically instead of using high temperatures. The streams of hot air remove the boundary layers of cool heavy air which tend to insulate the product. All Middleby ovens are designed to cook a multitude of products including pizza, seafood, sandwiches, bagels, ethnic foods and more.



General Information

The PS540 conveyor oven is ideally suited for medium-duty restaurant needs. The oven can cook a wide variety of food products, including pizza, seafood and bagels.

Standard Features

- **Impingement PLUS!** low oven profile and dual air return
- **Patented EMS Energy Management System*** reduces gas consumption and increases cooking efficiency
- 40-1/2" (1029mm) long cooking chamber
- 32" (813mm) wide, 76-1/2" (1943mm) long conveyor belt
- Patented "Jet Sweep" impingement process that delivers constant heat to the chamber
- Stackable up to three units high
- Microprocessor-controlled bake time/conveyor speed
- Customer-specific adjustable jet fingers that allow control of heating delivery
- Stainless steel front, sides, top and interior
- Front-loading window with cool handle
- Reversible conveyor direction

Optional Features

- Split belt - two 15" (381mm) belts with individually adjustable speed settings
- High speed conveyor (Range of 1:00 - 10:00)
- Adjustable legs (replace casters)
- Stainless steel lower shelf on double and triple oven

Conserves Energy

Unit incorporates a patented Energy Management System - EMS. Middleby ovens provide very efficient heat transfer to product. Energy is conserved as air is recycled from heater to product, with minimum loss. Oven is cool to the touch.

Cleanability

PS540 Ovens are designed for easy cleaning. Removable parts include: crumb pans, end panels, air fingers, exit tray, and a removable conveyor belt assembly.

Easily Services

Control compartment is designed for quick and easy access.

Warranty

All PS540 models have a one year parts and labor warranty.

Ventilation

Use of a ventilation hood is required.

**Photos show ovens equipped with casters. Some installation codes require the use of adjustable feet instead of casters.*

NOTE: Drawings show ovens equipped with casters.
CE-approved units use adjustable feet instead of casters.

TOP VIEW

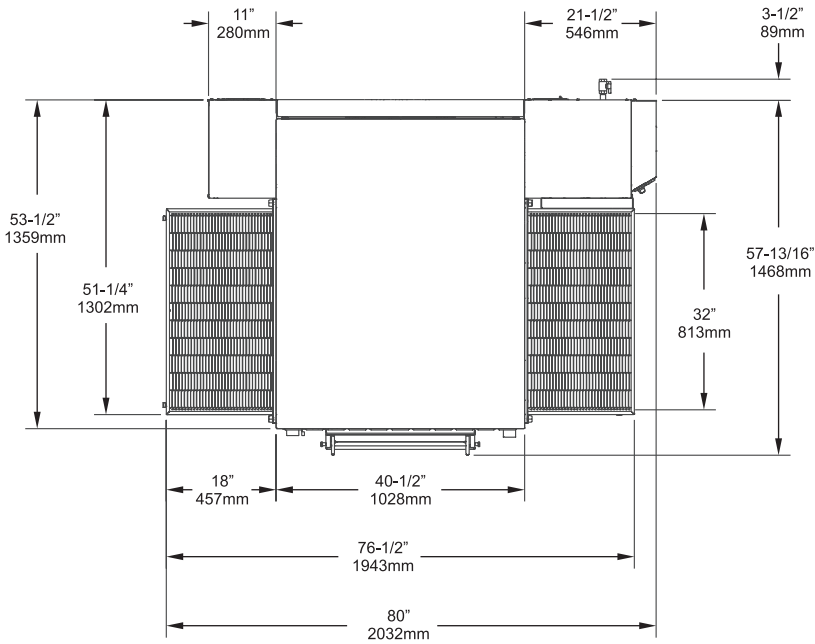

NOTE: All drawings show ovens equipped with casters. Adjustable feet that replace the casters are available as an option. CE-approved ovens require the use of adjustable feet.

- ① GAS INLET
- ② ELECTRICAL JUNCTION BOX

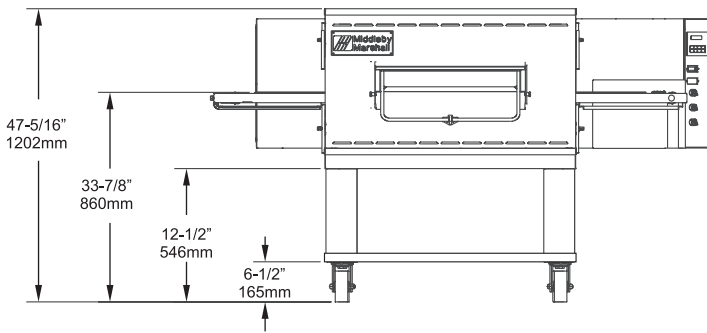

FRONT VIEW

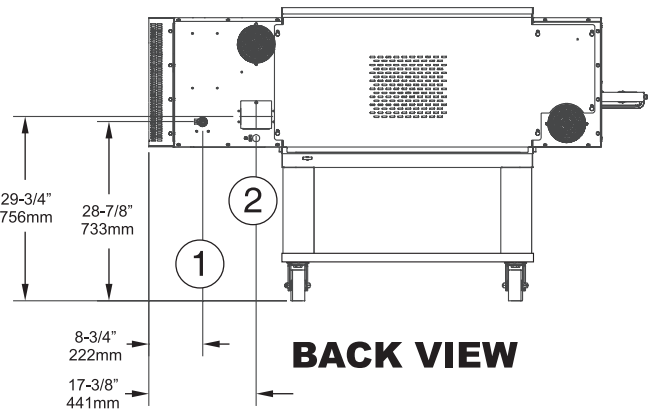

BACK VIEW

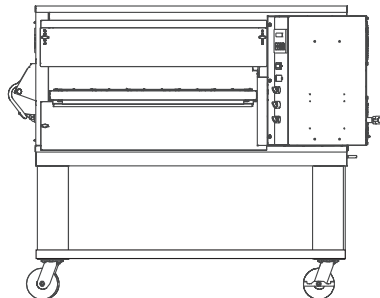

SIDE VIEW

**PS540 Series
Direct Gas Fired Conveyor Oven**

NOTE: Drawings show ovens equipped with casters.
CE-approved units use adjustable feet instead of casters.

PS540-2

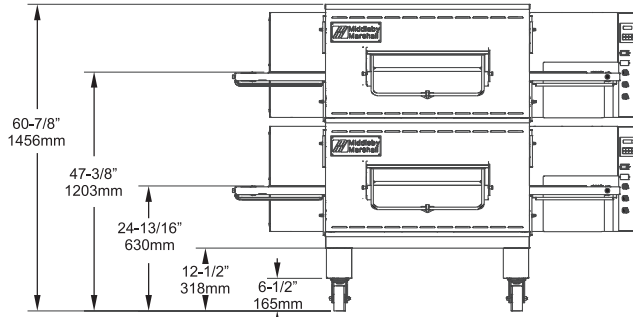

FRONT VIEW

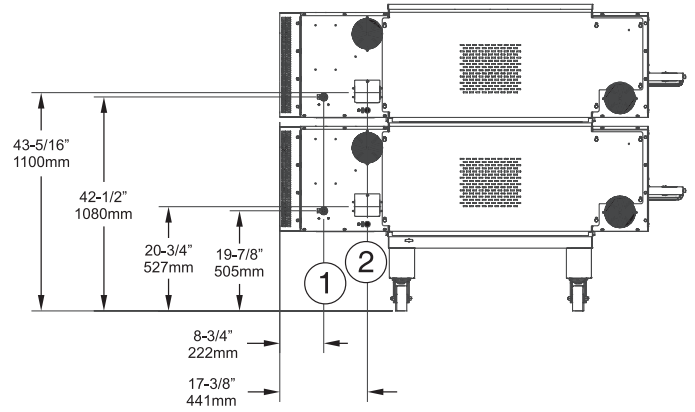

BACK VIEW

- ① GAS INLET
- ② ELECTRICAL JUNCTION BOX

PS540-3

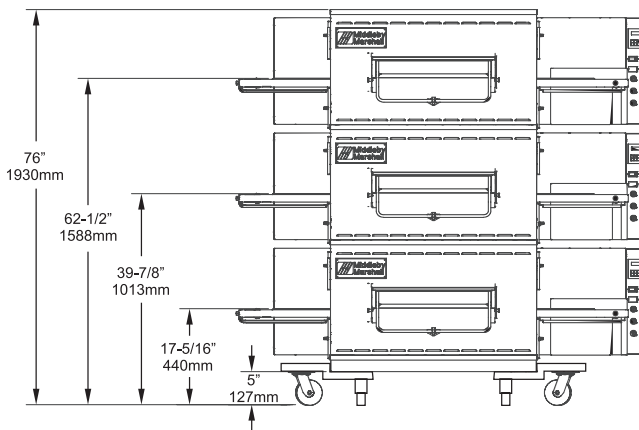

FRONT VIEW

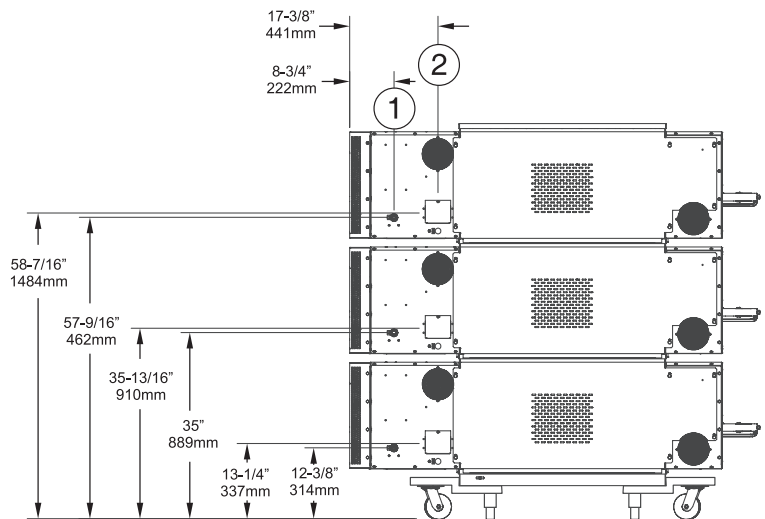

BACK VIEW

RECOMMENDED MINIMUM CLEARANCES

Rear of Oven to Wall	Control end of conveyor to wall	Non-control end of conveyor to wall
0"	0"	0"

GENERAL SPECIFICATIONS

	Heating Zone	Baking Area	Belt Length	Belt Width	Length	Height	Depth	Maximum Operating Temp	Bake Time Range	Ship Wt	Ship Cube
PS540-1	40-1/2" 1028mm	9sq.ft. 0.837m ²	76-1/2" 1943mm	1x32" (813mm) or 2x15"(381mm)	80" 2032mm	47-5/16" 1202mm	60-1/2" 1537mm	550°F 288°C	3:00-30:00 or 1:00-10:00	1100lbs. 499kg	132ft ³ 3.70m ³
PS540-2	81" 2056mm	18sq.ft. 1.674m ²	76-1/2" 1943mm	1x32" (813mm) or 2x15"(381mm)	80" 2032mm	60-7/8" 1546mm	60-1/2" 1537mm	550°F 288°C	3:00-30:00 or 1:00-10:00	2200lbs. 999kg	264ft ³ 7.39m ³
PS540-3	121.5" 3084mm	27sq.ft. 2.511m ²	76-1/2" 1943mm	1x32" (813mm) or 2x15"(381mm)	80" 2032mm	76" 1930mm	60-1/2" 1537mm	550°F 288°C	3:00-30:00 or 1:00-10:00	3300lbs. 1498kg	396ft ³ 11.09m ³

ELECTRICAL SPECIFICATIONS

Version	Voltage	Phase	Freq	Current Draw	Supply	Breakers
USA & std export	208-240v	1	50/60Hz	4.1 Amp	3 wire (2 hot, 1 ground)	As per local codes
Europe (CE)	220-230v	1	50Hz	4.1 Amp	3 wire (2 hot, 1 ground)	As per local codes

* The current draw rating shown above are maximum values for normal operation, amperage draw will be less than the listed value.
NOTE: Each oven includes a 6' cord with NEMA# L6-20P plug. Customer to provide NEMA# L6-20R receptacle

GAS SUPPLY SPECIFICATIONS

Version	Gas Type	North America	IE,IT,PT,ES,GB II _{2H3+}	DE II _{2ELL3B/P}	NL II _{2L3B/P}	BE, FR II _{2E+3+}	AT,CH,DK,FI,SE II _{2H3B/P}	Rated Heat Input
USA & std. export	Natural Gas	6-12" W.C. (14.9-29.9mbar)	-	-	-	-	-	110,000BTU (32.23kW-hr)
USA & std. export	Propane Gas	11-14" W.C. (27.4-34.9mbar)	-	-	-	-	-	110,000BTU (32.23kW-hr)
Europe (CE)	G20	-	20mbar	20mbar	-	20-25mbar	20mbar	32.23kW-hr
Europe (CE)	G25	-	-	20mbar	25mbar	-	-	32.23kW-hr
Europe (CE)	G20, G25	-	20mbar	20mbar	25mbar	20-25mbar	20mbar	32.23kW-hr
Europe (CE)	G30	-	29-37mbar	-	28-30mbar	29-37mbar	50mbar	32.23kW-hr
Europe (CE)	G30, G31	-	-	50mbar	30mbar	-	50mbar	32.23kW-hr

The required gas supply pressures of other locations are dependent on the local gas type and on all applicable local codes.

Minimum Gas Pipe Sizes:

* Natural Gas - 2" (51 mm) main supply line. One 3/4" (19mm) NPT branch per oven cavity with individual full-flow shutoff valve.

* Propane Gas - 1 1/2" (31.8 mm) main supply line. One 3/4" (19mm) NPT branch per oven cavity with individual full-flow shutoff valve

NOTE: Each oven includes (1) 3/4"(19mm)NPT x 48"(1219mm) flexible, vinyl coated stainless steel braided gas hose.

ALL SPECIFICATIONS SUBJECT TO CHANGE WITHOUT NOTICE.